

Think of tomorrow and make
intelligent investment today

..... Solar Energy in Service of Industry

SOLAR WATER HEATER
Sooryaja®

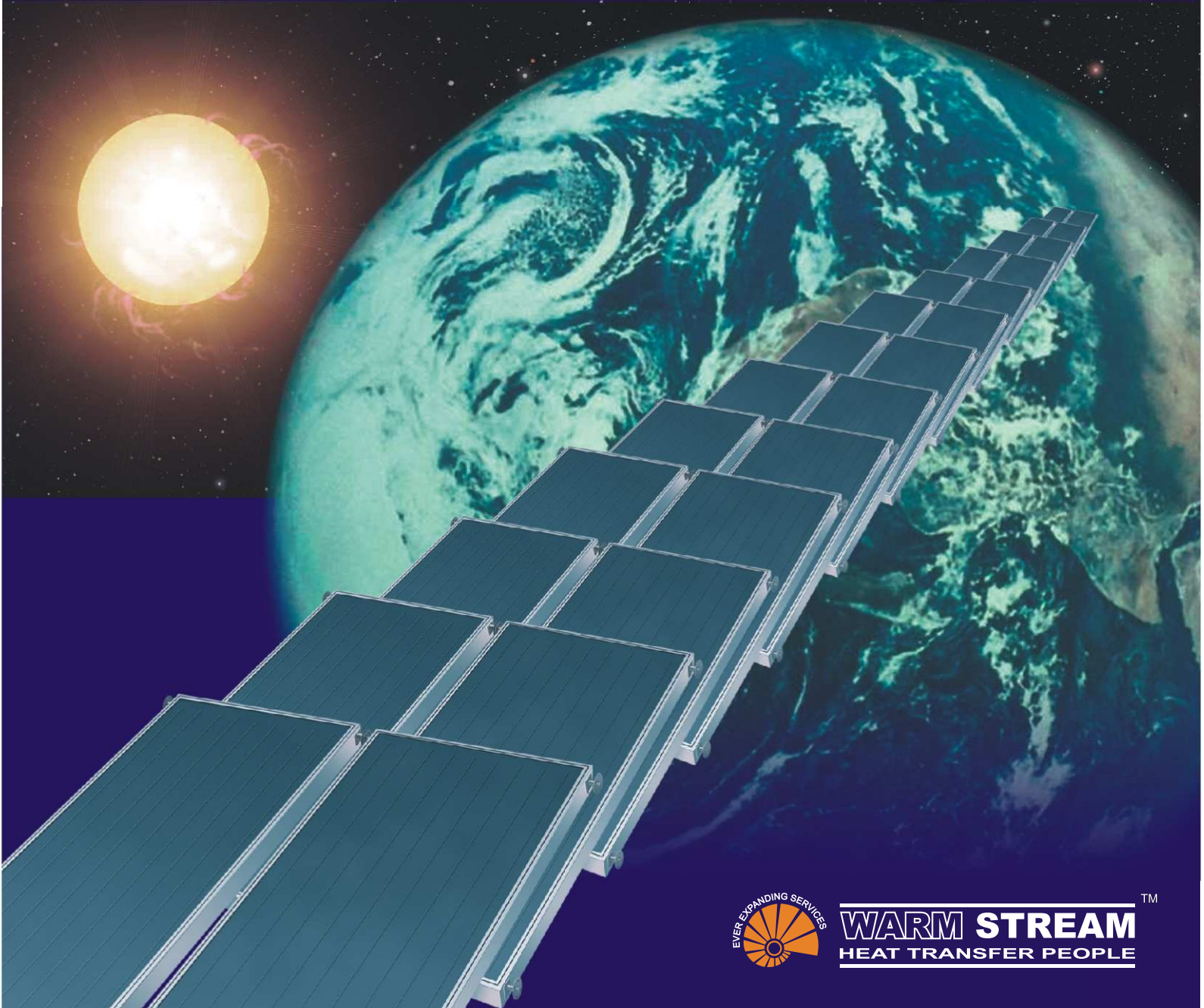

WARM STREAM™
HEAT TRANSFER PEOPLE

Component's Specification

STORAGE WATER TANK: Corrosion proof Storage Tank made from mild steel, SS 304 or SS 316 Sheets.

COLLECTOR CASING: Aluminium extruded sections of 16 swg thickness, Weather tight construction, duly anodised and corrosion resistant.

GLAZING: Single pan 4 mm. thick, low Iron toughened glass, rupture resistant and over 85% transmittance and low reflectance to eliminate glare.

ABSORBER PLATE: Made of grooved copper sheet and copper tube structure soldered to each other providing maximum contact area for excellent heat transfer between sheet and tubes. The absorber plate is coated with black nickel chrome coating to produce a superior selective surface having 95% absorption and very low emission of 20%.

ALUMINIUM FOIL: Attached to the insulation to reflect the emitted heat radiation to the absorber plate, thus minimising heat loss at the back.

INSULATION: High density rock wool slabs are used at bottom and sides of the absorber plate to minimize heat loss.

BACK PAN: Made of Aluminium Sheet 20 swg thick duly anodised.

TUBING GRID: 12 mm. Copper water way silver-brazed to 25 mm. copper manifold with an optimal ratio between diameters.

PIPING CONNECTION: Can be made at four locations with the help of bolts and nuts with rubber seals between the joints.

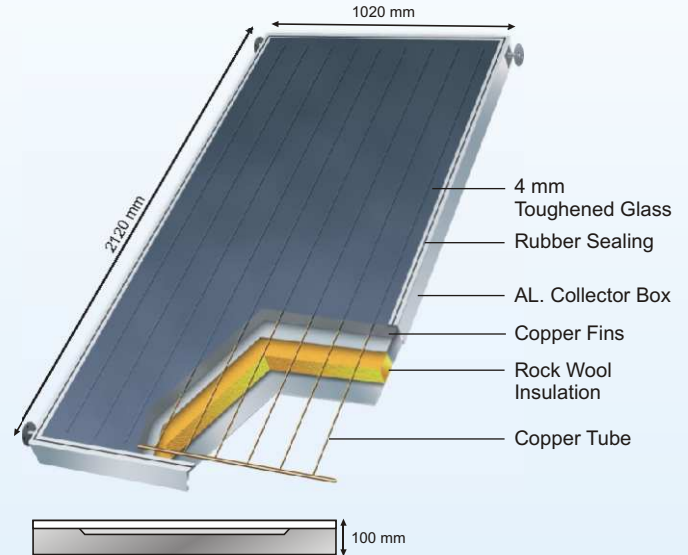

Salient Features

- Easy to Install.
- Durable.
- Saves Energy.
- High operating efficiency.
- High Standards of quality.
- Accident Free.
- Suitable for heating fluids up to 85° C.
- The most luxurious way of getting hot water.
- Quick return on investment.
- 100% depreciation for commercial use.

Savings

Yearly fuel savings if 100 LPD system is installed (calculated for 320 working days, at 60°C)

	FUEL	CALORIFIC VALUE	EFFICIENCY	FUEL SAVED
1	Fire Wood	3900 Kcal/kgs	60 %	685 kgs/annum
2	Kerosene	9110 Kcal/kgs	65 %	340 Ltrs./annum
3	LPG	11700 Kcal/kgs	75 %	184 kgs/annum
4	Charcoal	5500 Kcal/kgs	70 %	416 kgs/annum
5	Diesel	10004 Kcal/kgs	75 %	252 Ltrs./annum
6	Electricity	860 Kwh	95 %	1960 kwh

Collector's Specifications

TECHNICAL SPECIFICATION OF SOLAR COLLECTORS:

Overall Dimensions	2120 x 1020 x 100 mm
Temperature Range	up to 85°C
Test Pressure	5 kgs/cm ²

ABSORBER

Fin Material	Copper
Surface Coating	Selectively Coated (black Nickel Chrome)
Headers/ Risers / Flanges	Copper
Enclosure Material	Aluminium extruded section
Insulation (48 kgs/m ³)	Rock Wool/Spintex 300 or equivalent
Cover Plate	Toughened Glass - 4 mm.





We, at WARM STREAM are in water Heating business since middle of 1974 and are successfully manufacturing Wood Fired, Oil Fired and Gas Fired Water Heaters. Our sister concern ENERGY MACHINE manufactures Industrial range consisting of different Heat Generation Equipments.

Solar Energy, available in abundance and free of cost inspired us to explore the possibility of its utilization both for commercial and domestic requirements for benefit of the nation to Save on Costly Fuels. And we became the pioneers in the Solar Water Heating Business.

Innovation backed with experience brought to the Fore our 'SOORYAJA' SOLAR WATER HEATING SYSTEMS which are unique, reliable, energy efficient and easy to install.

They are well accepted both for Domestic and Commercial use in the country.

RANGE OF OUR PRODUCTS

Wood Fired Water Heaters, Automatic / Manual -- Gas / Diesel Fired Water Heaters, Instant Gas Geysers etc.



ISO 9001 : 2000 Certified Company



WARM STREAM
HEAT TRANSFER PEOPLE

ANAND-SOJITRA ROAD, P.O.BOX.No. 22.
V. U.NAGAR, GUJARAT - 388 121, INDIA

Tel.: (02692) 31316,32309 Fax: 36478
E-mail: warmstream@warmstream.co.in

Web Site: www.warmstream.co.in
www.warmstream.net



INDUSTRIAL/COMMERCIAL

SOLAR WATER HEATING SYSTEM:

Industrialisation always brings with itself a bright future by way of innovative and efficient handling of products both conventional and non-conventional. SOLAR ENERGY is the key non-conventional source which when used effectively leads to better returns on Investments. The continuous flow of solar energy unaffected by power cuts or transmission losses; it's **safety** and **low maintenance** requirements; and on top of it, all this is **absolutely pollution free**. Sun is the only energy source which still continues to operate without any sign of decline.



How It Works?

The Industrial / Commercial Solar Water Heating Systems are designed to supply water at 80° C. Sun rays pass through the transparent glass of the collector and strike on the black surface of the absorber. The black coating on the absorber converts the radiation energy into the heat energy. This heat is transferred to the tubes; thereby heating the water inside the tubes. Forced flow circulation system with Thermostatically controlled, fixed or differential temperature controller is installed. The system consists of an array of collectors, arranged in a series / parallel combination so as to optimise the pressure drop as well as the heat collection, while utilising the available space to the maximum. A motor pump is used to circulate water through the collectors. This pump is activated by a capillary type thermostat with the rise in the temperature from the preset condition. The heated water is supplied to a properly insulated storage tank which can keep it hot overnight.

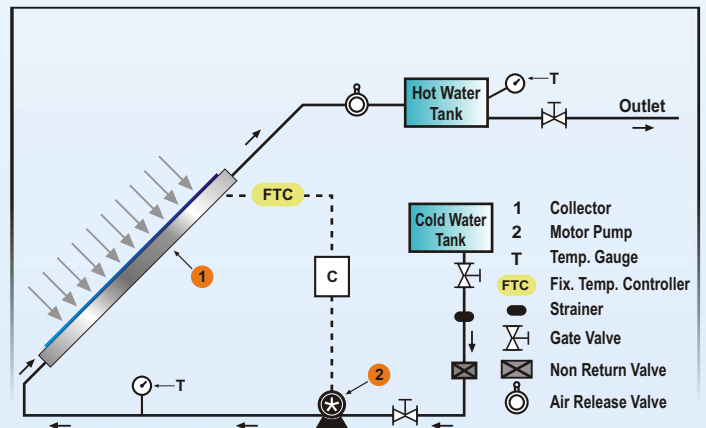

Almost 3 decades of continuous development, combined with vast experience and extensive research has established 'SOORYAJA' Solar Water Heating Systems as leaders in the market. Today, 'SOORYAJA' not only represents highly specialized technology and experience, but high quality systems which meet the highest demands. **Warm Stream** being an **ISO 9001: 2000** certified company, all the products are thoroughly inspected at every stage to ensure the highest quality standards. 'SOORYAJA' is manufactured as per IS-12933 Part-1.

'SOORYAJA' Solar System has a payback period of 1-2 years when compared to electric heaters and of 3-4 years when compared to oil fired boilers. Solar Water Heating Systems are even more beneficial, as the prices of conventional fuels are not likely to decrease in the future.

Think of tomorrow and make an intelligent investment today.

Install 'SOORYAJA' Solar Water Heating System and let 'Sun' do the rest.